



American Fabric Filter Co.

Your ultimate source for dust bags, screens and rubber products!

Drum-Top Dust Collector Bags

10 oz. Shaker Felt, Singed Inside 2012 Price List

Maximize the performance of your small or mid-sized container-topped dust collector with an AFF oversized filter bag -- the most cost-effective way to increase suction and reduce the amount of dust in your shop. Replace that ineffective 30 micron woven cloth filter bag with our singed felt bag and get enough fabric surface area to exhaust all the air (CFM) without producing back-pressure. Regain maximum fan output and still contain virtually all the finest dust. All bags listed here are rated for twice the fan CFM and will continue providing great suction and very fine dust filtration even after the fabric gets dirty.

American Fabric Filter Co. custom makes bags of all sizes and shapes. Years of experience have taught us that the designs suggested here work best for general applications. **For commercial duty applications, we strongly recommend using 12 oz. and 16 oz. felts and making the bag one and two sizes larger respectively.** Please call us to discuss your specific needs.

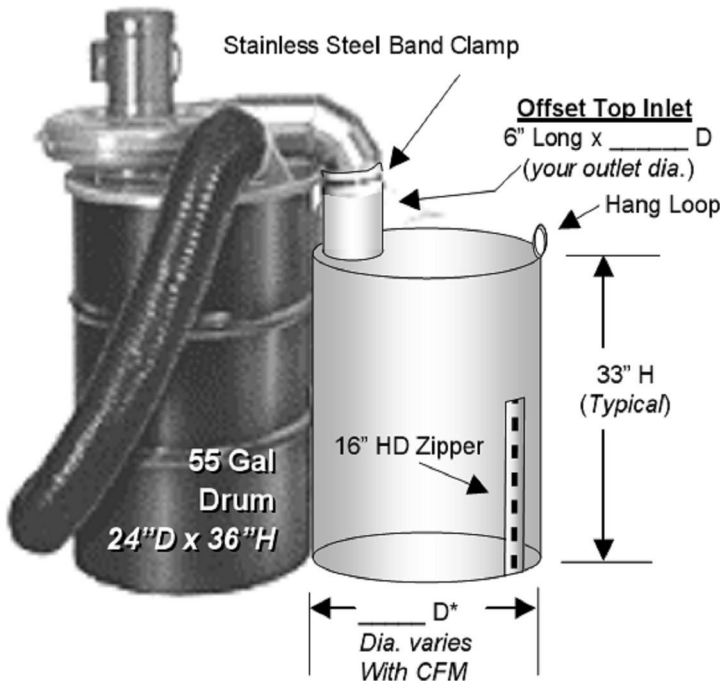

← **Smaller Systems**

MOTOR H.P.	FAN CFM	BAG DIA	2012 PRICES
1/3	335	20"D x 24"H	\$ 88.98
1/2	450	22" D x 33"H	\$ 93.63
3/4	580	25" D x 33"H	\$ 97.05
1	700	29" D x 33"H	\$ 102.09
1-1/2	875	35" D x 33"H	\$ 112.54

Call, fax or e-mail us for a no-obligation evaluation of your equipment's performance and a free quote.

P.O. Box 7560
 Wesley Chapel, FL 33545
info@Americanfabricfilter.com
www.AmericanFabricFilter.com



800-367-3591

813-991-9400

Fax: 813-991-9700



American Fabric Filter Co.

Your ultimate source for dust bags, screens and rubber products!

Large Systems



MOTOR H.P.	FAN CFM	BAG HEIGHT	2011 PRICES
1	700	22"D* x 48"H	\$ 110.19
1-1/2	875	24"D x 54" H	\$ 124.88
2	1100	24"D x 72" H	\$ 132.57
3	1300	24"D x 84" H	\$ 138.69
2hp/16 oz 3hp/12 oz		30"D x 79" H	\$ 168.68
3 hp/16 oz		36"D x 79" H	\$ 196.03

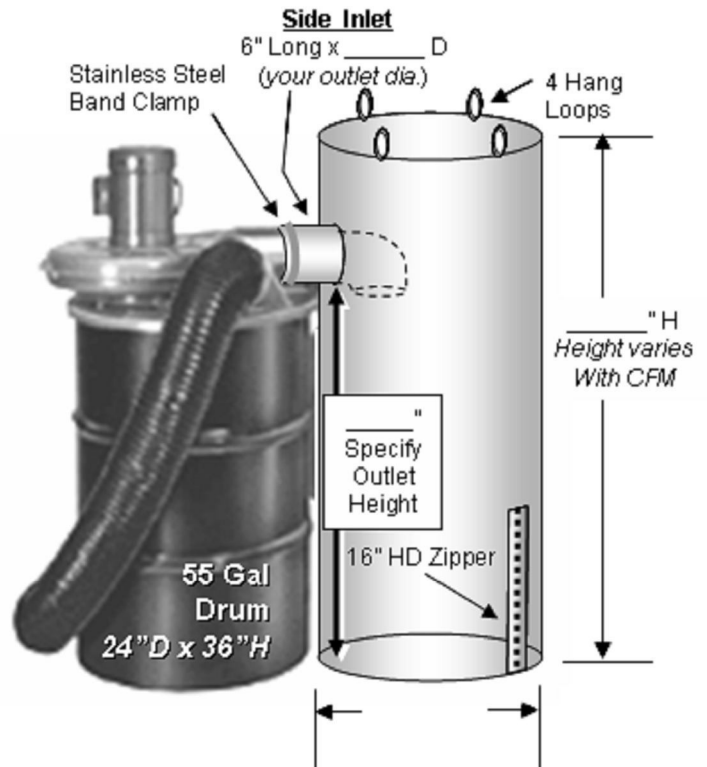

Optional Blower Output Band Clamps

4" Dia. @ \$ 5.00 ea.	6" Dia. @ \$ 6.00 ea.	10" Dia. @ \$ 8.00 ea.
-----------------------	-----------------------	------------------------

Call, fax or e-mail us for a no-obligation evaluation of your equipment's performance and a free quote.

P.O Box 7560
 Wesley Chapel, FL 33545
info@Americanfabricfilter.com
www.AmericanFabricFilter.com

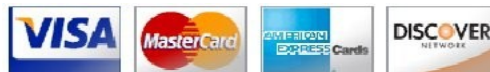

800-367-3591

813-991-9400

Fax: 813-991-9700